

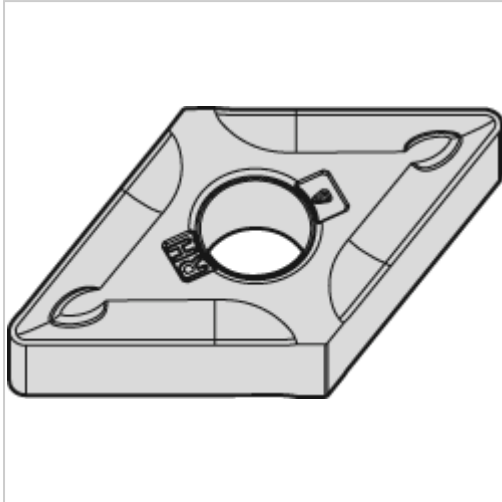

## Wendeschneidplatte ZrCN DNMG 150616 RH WP25CT



# WIDIA

## €18.33\*

Prices incl. VAT plus shipping costs

Art nr.: **196573WP25CT**

### Properties

Bearbeitung:	Schruppen
Beschichtung:	ZrCN
Drehrichtung der Schneidplatte:	rechts
Einsatzgebiet:	Gusseisen, Stahl
Schnitt:	stark unterbrochener schnitt

### Variants

Code	ISO-Code	Schneidstoff	Spanbrecher	Spanleitstufe	PU	Price/PU
<b>196573WP25CT</b>	<b>DNMG 150616 RH</b>	<b>WP25CT</b>	-	-	<b>1 pices</b>	<b>€18.33</b>
196572WP25CT	DNMG 150612 RH	WP25CT	Ja	RH	1 pices	€18.33